

REVISIONS	
ISS	DESCRIPTION \ DATE

RoHS COMPLIANT

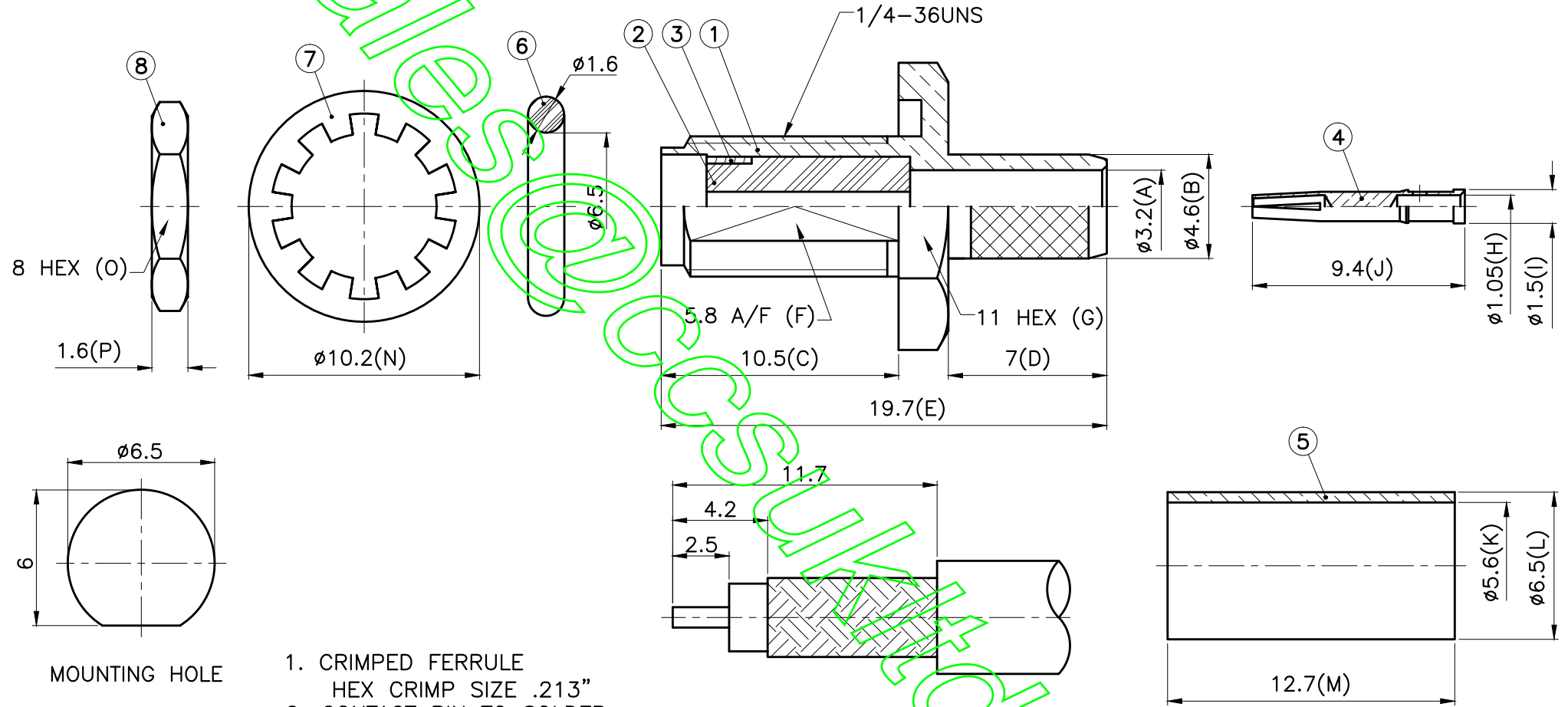

- 1. CRIMPED FERRULE
HEX CRIMP SIZE .213"
- 2. CONTACT PIN TO SOLDER

RECOMMENDED
CABLE STRIPPING DIM'S



TITLE: SMA FEMALE CRIMP B/H
(FOR RG58)

PART NO: SMABJCR58

DRAWING NO: 029

APRD:	UNLESS OTHERWISE SPECIFIED TOLERANCES 0.5-6 = ±0.2 >6-30 = ±0.4 >30-120 = ±0.6 >120-315 = ±1 >315-1000 = ±1.6 ANGLES = ±5°	8	NUT	BRASS	GOLD
CHKD:		7	WASHER	STEEL	GOLD
DR:		6	GASKET	SILICONE	RED
DATE: 11/22/13"	UNIT: mm	5	FERRULE	BRASS	GOLD
SHEET: .	SCALE: 4/1	4	CONTACT PIN	PHOSPHOR BRONZE	GOLD
		3	LOCK RING	BRASS	GOLD
		2	INSULATOR	TEFLON	WHITE
		1	BODY	BRASS	GOLD
		NO.	DESCRIPTION	MATERIAL	FINISH